



KVC (UK) Ltd.



Ball Valves

Company Profile

KVC (UK) Ltd.

The company, which is part of the Federal International 2000 group, was established in 1989.

It specialises in the Design and Manufacture of Ball Valves for the Oil, Gas, Chemical, Petrochemical, Pipeline and Water Industries worldwide. Our valves are used in offshore, onshore and sub-sea applications.

The aim of **KVC (UK) Ltd** is to provide valves and associated services that meet or exceed our customer's requirements at a realistic and competitive price. All valves are manufactured to the highest quality standards and are fully tested before leaving the factory.

The Management of the Company has many years experience in the Valve industry, and the organisation and flexibility of the company allows **KVC (UK) Ltd** to offer short leadtimes, even on non-standard valves.

KVC (UK) Ltd uses computerised systems to control the design and manufacture of the product and to ensure the latest technical and material innovations are recognised.

Our product range covers both Floating Ball and Trunnion Mounted Valves from 1/2" thru 24", both full and reduced bore, and in pressure classes 150 thru 2500. Valves are manufactured in a wide range of materials from Carbon Steel to Super Duplex. Valves are offered in Soft Seated or Metal Seated Options. Other products within our supply range include Gate, Globe, Check and Forged Steel valves.

KVC (UK) Ltd quality system is Lloyds approved to BS: EN ISO 9001, which ensures that our product is controlled through each stage of manufacture. Valves are supplied with full chemical and mechanical material test certificates to BS 10204 3.1 B. Hydrostatic and Pneumatic test certificates are also supplied with each valve.

Full customer support through each stage of manufacture completes the Package, which makes **KVC (UK) Ltd** valves an excellent choice for valve end users and engineering companies worldwide.

Applicable Standards

KVC (UK) Ltd. design and manufacture valves in accordance with latest edition of **API**, **ASTM**, **ASME** and **B.S. MSS**, **NACE** standards. The valves may be designed, manufactured and tested in accordance with other international standards on request.

API – AMERICAN PETROLEUM INSTITUTE

- Spec. 6A Specification for wellhead and christmas tree equipment.
- Spec. 6D Specification for pipeline valves.
- Spec. 607 Specification for firetesting of valves.
- Std. 598 Valve inspection and test.
- Spec. Q1 Specification for quality programs

ASME – AMERICAN SOCIETY OF MECHANICAL ENGINEERS

- B 16.5 Steel pipe flanges and flanged fittings.
- B 16.10 Face to Face and end to end dimensions of ferrous valves.
- B 16.25 Butt welding ends.
- B 16.34 Steel valves - Flanged and butt welding ends.

ASTM – AMERICAN SOCIETY FOR TESTING AND MATERIALS

BS – BRITISH STANDARD

- BS 2080 Face to face, centre to face, end to end, and centre to end dimensions of flanged and butt-welded end steel valves for the petroleum, petrochemical and allied industries.
- BS 4504 Flanges and boltings for pipes valves and fittings.
- BS 5351 Steel ball valves for the petroleum, petrochemical and allied industries.
- BS 6755 Testing of valves.

ISO-INTERNATIONAL ORGANISATION FOR STANDARDIZATION

- EN-ISO 9001: 2000 Quality Management System Requirements

MSS-MANUFACTURER STANDARDIZATION SOCIETY

- SP 6 Standard finishes for contact faces of pipe flanges and connecting end flanges of valves and fittings.
- SP 25 Standard marking system for valves, fittings, flanges and unions.
- SP 45 By-pass and drain connection standard.
- SP 55 Quality standard for steel castings-visual method.
- SP 61 Hydrostatic testing of steel-valves.
- SP 72 Ball valves with flanged or butt-welded ends for general service.
- SP 44 Steel pipe line flanges.

NACE- NATIONAL ASSOCIATION OF CORROSION ENGINEERS

- MR-01-75 Sulfide stress cracking resistant metallic materials for oil field equipment.



Figure Number

K ↓	09 ↓	2 ↓	4 ↓	T ↓
TYPE OF BORE	ASME CLASS	BODY MATERIAL	TRIM MATERIAL	TYPE OF BALL
K=FULL BORE (2Pc & 3Pc Design)	01=CL 150 03=CL 300	1=LC3/LF3 2=WCB/A105	1=CF8C (347) 2=MONEL	T=Trunnion Without 'T'=Floating
R=Reduced Bore (2Pc & 3Pc Design)	06= CL 600 09 = CL900	3=CF8 4=CF8M	3=CF8 (304) 4=CF8M (316)	TM = Trunnion Metal Seated
1R=Reduced Bore (1 Pc Design)	15=CL 1500 25 = CL 2500	5=CF3 (304L) 6=DUPLEX 7=CF3M 8=CN7M/ALLOY 9=LCB/LCC/LF2 0=SPECIAL	5=CF3(304L) 6=DUPLEX (F51) 7=CF3M (316L) 8=CS + ENP 3MILS 9=CN7M (ALLY20) 0=SPECIAL	M =Floating Metal Seated

OPTIONS

SEATS	SEALS	BOLTINGS	ENDS
PEEK	GRAPHITE	A I93 B7/ A194 2H	BUTT WELD
PTFE	PTFE	A I93 B7M / A I94 2HM	RAISED FACE
RPTFE	GRAPHITE	A320 L7 / A I94 GR4	RING TYPE JOINT
NYLON	VITON 'B'	A320 L7M / A194 GR4	GRAYLOC HUB
PES	NITRILE	A320 B8 CLASS II / AI94 GR8	SOCKET WELD
DEVLON 'V'	AED	A320 B8M CLASS II / AI94 GR8M	SCREWED
SPECIAL	SPECIAL	ZINC PLATED AND/OR PTFE COATED	SPECIAL

Other materials available on request

GENERAL NOTES FOR DIMENSIONAL TABLES

- 1 . All sizes given in millimetres and are approximate.
2. All weights given in kgs and are approximate.
3. Weights given for flanged valves include gearbox unless otherwise stated.
4. Dimensions shown may be revised at any time. Use certified dimensional drawings for critical areas.

Technical Features

FLOATING BALL DESIGN

DESIGN

Floating Ball valves are manufactured in three main types;

One piece End Entry Type.

Two Piece Bolted Construction.

Three Piece Bolted Construction.

Valves can be supplied Full or Reduced Bore and are manufactured in either cast or forged construction.

Bolted and Screwed Body connections give ease of service and maintenance on site.

Valves can be supplied with either Raised Face, Ring Type Joint, Socket Weld or Screwed End connections.

Pressure rating is from ANSI 150 thru ANSI 2500. Higher pressures can be supplied on request. Valves are supplied with Lever or Gear Operator.



MATERIAL SELECTION

Valves are manufactured in a range of materials such as Carbon Steel, Low Temp Carbon Steel, Stainless Steel, Duplex, Super Duplex, Monel, Inconel and other Special Alloys.



BODY /CAP SEAL

Graphite rings, O rings or PTFE Seals guarantee perfect sealing between Body and Cap. The Graphite ring continues to provide a seal in the event of a fire. O rings can be supplied suitable for AED applications.

Technical Features



SEAT

Valve seat design gives a perfect seal with various materials in both high and low pressure applications.



STEM

Stems are manufactured separately from the Ball, and incorporate O Rings, Graphite rings and Anti-static devices.



BALL

Balls are supplied in Forged or Cast Stainless Steel, Duplex or Carbon Steel with ENP.



TESTS

Valves are tested in accordance with BS 6755 Pt 1, API 6D, API 598 and ASME B 16.34



FIRE TEST CERTIFICATION

Valves are certified by an Independent Authority according to API 607, BS 6755 Pt 2 and API 6FA.



EXTERNAL COATING

Carbon Steel valves are normally supplied with KVC standard paint finish. Valves can also be supplied unpainted or to customers paint specification.



ACCESSORIES

Include locking devices, pipe pups, extended bonnets and actuators. Suitable materials, components, seats and O rings can be supplied for valves with Explosive Decompression or Cryogenic applications

Floating Ball Valves

ONE PIECE FLOATING BALL • REDUCED BORE • ASME 150									
API 6 D		TEST PRESSURE 425 PSI						MAX. WP. 275 PSI	
SIZE	A RF	B	C	D	E	F	G	H	APPROX WEIGHT KG
1/2" x 3/8"	108.0	15.0	89.0	78.0	153.0	LEVER OPERATED			1.6
3/4" x 1/2"	117.0	20.0	99.0	78.0	153.0				2.5
1" x 3/4"	127.0	25.0	108.0	98.0	220.0				3.0
1 1/2" x 11/4"	165.1	38.0	127.0	118.0	250.0				6.0
2"x 1 1/2"	177.8	51.0	152.0	133.0	250.0				9.0
3" x 2"	203.2	76.0	191.0	156.0	250.0				16.0
4" x 3"	228.6	100.0	229.0	189.0	350.0				28.0
6" x 4"	393.7	150.0	279.0	209.0	460.0				50.0
8" x 6"	457.2	203.0	343.0	305.0	800.0				83.0
10" x 8"	533.4	254.0	406.0	335.0	800.0				375.0
8" x 6"	457.2	203.0	343.0	172.0	268.0	310.0	82.5	166.0	95.0
10" x 8"	533.4	254.0	406.0	203.0	298.0	310.0	82.5	166.0	160.0

ONE PIECE FLOATING BALL • REDUCED BORE • ASME 300									
API 6 D		TEST PRESSURE 1100 PSI						MAX. WP. 720 PSI	
SIZE	A RF	B	C	D	E	F	G	H	APPROX WEIGHT KG
1/2" x 3/8"	140.0	15.0	95.0	78.0	152.5	LEVER OPERATED			2.5
3/4" x 1/2"	152.0	20.0	117.0	80.0	153.0				4.2
1" x 3/4"	165.0	25.0	124.0	98.0	220.0				4.8
1 1/2" x 11/4"	190.5	38.0	156.0	118.0	250.0				8.6
2"x 1 1/2"	215.9	51.0	165.0	133.0	250.0				12
3" x 2"	282.58	76.0	210.0	156.0	250.0				24
4" x 3"	304.8	100.0	254.0	189.0	350.0				39
6" x 4"	403.23	150.0	318.0	209.0	460.0				65
8" x 6"	501.65	203.0	381.0	305.0	800.0				140
8" x 6"	501.65	203.0	381.0	190.5	268.0				310.0
10" x 8"	568.33	254.0	455.0	22.5	301.0	355.0	97.5	210.0	210

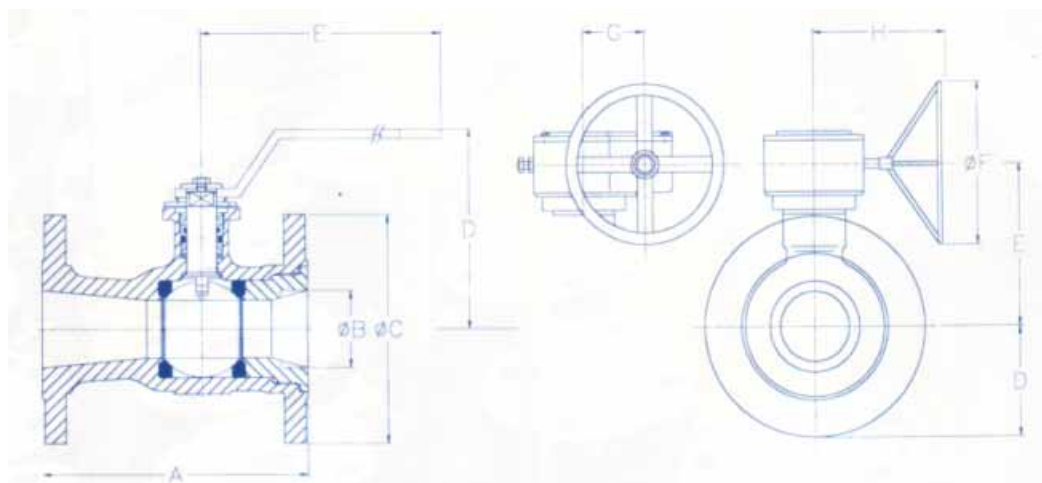

Floating Ball Valves

TWO PIECE FLOATING BALL • FULL AND REDUCED BORE • ASME 150											
API 6 D		TEST PRESSURE 425 PSI					MAX. WP. 275 PSI				
SIZE	A RF	B	B1	C	D	E	F	G	APPROX WEIGHT KG		
1/2" x 1/2"	108.0	15.0	N/A	88.9	98.1	130.0	LEVER OPERATED		2.1		
3/4" x 3/4"	117.6	19.8	N/A	98.6	100.6	130.0			2.6		
1" x 1"	127.0	25.4	N/A	108.0	111.5	130.0			3.5		
1 1/2" x 1 1/4"	165.1	38.1	31.8	127.0	139.0	299.7			6.2		
1 1/2" x 1 1/2"	165.1	38.1	N/A	127.0	139.0	299.7			7.0		
2" x 1 1/2"	177.8	50.8	38.1	152.4	139.0	299.7			9.0		
2" x 2"	177.8	50.8	N/A	152.4	145.1	299.7			9.4		
2 1/2" x 2"	190.5	63.5	50.8	177.8	145.1	299.7			13.2		
3" x 2"	203.2	76.2	63.5	190.5	182.9	398.8			18.5		
3" x 3"	203.2	76.2	N/A	190.5	192.1	398.8			20.7		
4" x 3"	228.6	101.6	76.2	228.6	192.1	398.8			27.2		
4" x 4"	228.6	101.6	N/A	228.6	220.5	500.4			33.4		
6" x 4"	266.7	152.4	101.6	279.4	220.5	500.4			45.6		
6" x 6"	393.7	152.4	N/A	279.4	296.7	800.1			76.7		
8" x 6"	292.1	203.2	152.4	342.9	296.7	800.1			89.0		
6" x 6"	393.7	152.4	N/A	279.4	253.0	299.7			89.9	240.0	95.1
8" x 6"	292.1	203.2	152.4	342.9	253.0	299.7			89.9	240.0	97
8" x 8"	457.2	203.2	N/A	203.2	304.0	398.8	89.9	350.5	134		
10" x 8"	330.2	254.0	203.2	406.4	304.8	398.8	89.9	350.5	152		
10" x 10"	533.4	254.0	N/A	254.0	348.0	500.0	141.5	350.5	224		
12" x 10"	355.6	304.8	254.0	482.6	348.0	500.4	141.5	350.5	246		

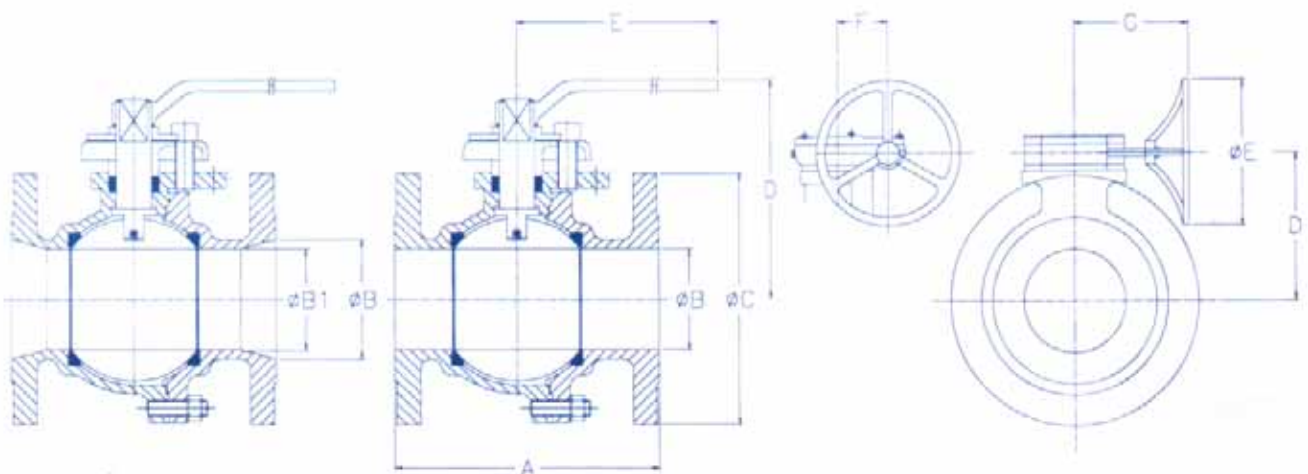

Floating Ball Valves

TWO PIECE FLOATING BALL • FULL AND REDUCED BORE • ASME 300											
API 6 D		TEST PRESSURE 1100 PSI					MAX. WP. 720 PSI				
SIZE	A RF	B	B1	C	D	E	F	G	APPROX WEIGHT KG		
1/2" x 1/2"	139.7	15.0	N/A	95.3	98.1	130.0	LEVER OPERATED		2.4		
3/4" x 3/4"	152.4	19.8	N/A	117.3	100.6	130.0			4.2		
1" x 1"	165.1	25.4	N/A	124.0	111.5	130.0			5.4		
1 1/2" x 1 1/4"	165.1	38.1	31.8	127.0	139.0	299.7			6.0		
1 1/2" x 1 1/2"	190.5	381.0	N/A	155.4	139.0	299.7			11.2		
2" x 1 1/2"	177.8	50.8	38.1	152.4	139.0	299.7			8.0		
2" x 2"	215.9	50.8	N/A	165.1	145.1	299.7			13.8		
2 1/2" x 2"	190.5	63.5	50.8	177.8	145.1	299.7			13.2		
3" x 2"	203.2	76.2	63.5	190.5	182.9	398.8			16.8		
3" x 3"	282.6	76.2	N/A	209.6	195.6	398.8			31.6		
4" x 3"	228.6	101.6	76.2	228.6	192.1	398.8			26.2		
4" x 4"	304.8	101.6	N/A	254.0	220.5	500.4			47.6		
6 " x 4"	266.7	152.4	101.6	279.4	220.5	500.4			46.4		
6" x 6"	403.2	152.4	N/A	317.5	296.7	800.1			99.6		
8" x 6"	292.1	203.2	152.4	342.9	296.7	800.1			91.0		
6" x 6"	403.2	152.4	N/A	317.5	253.0	299.7			74.9	317.5	118
8" x 6"	292.1	203.2	152.4	342.9	253.0	299.7			89.9	240.0	89
8" x 8"	501.7	203.2	N/A	381.0	304.8	398.8			89.9	350.5	171
10" x 8"	330.2	254.0	203.2	406.4	304.8	398.8			89.9	350.5	152
10" x 10"	568.3	254.0	N/A	444.5	348.0	500.0			141.5	350.5	288
12" x 10"	355.6	304.8	254.0	482.6	348.0	500.4	141.5	350.5	246		

TWO PIECE FLOATING BALL • FULL AND REDUCED BORE • ASME 600											
API 6 D		TEST PRESSURE 2175 PSI					MAX. WP. 1440 PSI				
SIZE	A RF	B	B1	C	D	E	F	G	APPROX WEIGHT KG		
1/2" x 1/2"	165.1	15.0	N/A	95.3	113.1	150.0	LEVER OPERATED		3.7		
3/4" x 3/4"	190.5	198.0	N/A	117.3	112.5	150.0			5		
1" x 1"	215.9	25.4	N/A	124.0	163.1	300.0			7		
1 1/2" x 1 1/2"	241.3	38.1	N/A	155.4	171.1	300.0			13		
2" x 1 1/2"	292.1	51.0	38.1	165.1	125.0	365.0			18		
2" x 2"	292.1	51.0	N/A	165.1	130.0	365.0			26		
3" x 2"	355.6	76.0	51.0	209.5	130.0	365.0			30		
3" x 3"	355.6	76.0	N/A	209.5	195.0	365.0			53		
4" x 3"	432.0	100.0	76.0	273.0	195.0	365.0			67		
4" x 4"	431.8	100.0	N/A	273.0	248.0	800.0			93		
6 " x 4"	558.8	152.0	100.0	355.6	248.0	800.0			120		
6" x 6"	558.8	152.0	N/A	355.6	295.0	800.0			178		
8" x 6"	660.1	203.0	152.0	419.1	295.0	800.0			182		
3" x 3"	355.0	76.0	N/A	209.5	195.0	310.0			62.5	165.0	60
4" x 3"	432.0	100.0	76.0	273.0	195.0	310.0			62.5	165.0	74
4" x 4"	432.0	100.0	N/A	273.0	248.0	310.0			62.5	165.0	100
6" x 4"	559.0	152.0	100.0	355.6	2 48.0	310.0			62.5	165.0	127
6" x 6"	559.0	152.0	N/A	355.6	295.0	355.0			97.5	210.0	185
8" x 6"	660.4	203.0	152.0	419.1	295.0	355.0			97.5	210.0	189

Floating Ball Valves

TWO PIECE FLOATING BALL • FULL AND REDUCED BORE • ASME 900									
API 6 D		TEST PRESSURE 3250 PSI						MAX. WP. 2160 PSI	
SIZE	A RF	A RTJ	A BWE	B	B1	C	D	E	APPROX WEIGHT KG
1/2" x 1/2"	216.0	216.0	216.0	14.0	N/A	120.6	95.0	276.0	12
3/4" x 1/2"	229.0	229.0	229.0	14.0	20.0	130.0	95.0	276.0	14
3/4" x 3/4"	229.0	229.0	229.0	19.0	N/A	130.0	95.0	276.0	18
1" x 3/4"	254.0	254.0	254.0	19.0	25.0	149.3	95.0	276.0	20
1" x 1"	254.0	254.0	254.0	25.0	N/A	149.3	105.0	276.0	24
1 1/4" x 1"	279.0	279.0	279.0	25.0	32.0	158.7	105.0	276.0	27
1 1/2" x 1 1/2"	305.0	305.0	305.0	38.0	N/A	117.8	130.0	365.0	32
2" X 1 1/2"	368.0	368.0	368.0	38.0	50	216.0	130.0	365.0	35

TWO PIECE FLOATING BALL • FULL AND REDUCED BORE • ASME 1500									
API 6 D		TEST PRESSURE 5400 PSI						MAX. WP. 3600 PSI	
SIZE	A RF	A RTJ	A BWE	B	B1	C	D	E	APPROX WEIGHT KG
1/2" x 1/2"	216.0	216.0	216.0	14.0	N/A	120.6	95.0	276.0	16
3/4" x 1/2"	229.0	229.0	229.0	14.0	20.0	130.0	95.0	276.0	14
3/4" x 3/4"	229.0	229.0	229.0	19.0	N/A	130.0	95.0	276.0	18
1" x 3/4"	254.0	254.0	254.0	19.0	25.0	149.3	95.0	276.0	20
1" x 1"	254.0	254.0	254.0	25.0	N/A	149.3	105.0	276.0	26
1 1/4" x 1"	279.0	279.0	279.0	25.0	32.0	158.7	105.0	276.0	27
1 1/2" x 1 1/2"	305.0	305.0	305.0	38.0	N/A	177.8	130.0	365.0	32
2" X 1 1/2"	368.0	368.0	368.0	38.0	50.0	216.0	130.0	365.0	35

TWO PIECE FLOATING BALL • FULL AND REDUCED BORE • ASME 2500									
API 6 D		TEST PRESSURE 9000 PSI						MAX. WP. 6000 PSI	
SIZE	A RF	A RTJ	A BWE	B	B1	C	D	E	APPROX WEIGHT KG
1/2" x 1/2"	264.0	264.0	264.0	14.0	N/A	133.3	95.0	276.0	18
3/4" x 1/2"	273.0	273.0	273.0	14.0	20.0	139.7	95.0	276.0	18
3/4" x 3/4"	273.0	273.0	273.0	19.0	N/A	139.7	95.0	276.0	25
1" x 3/4"	308.0	308.0	308.0	19.0	25.0	158.7	95.0	276.0	25
1" x 1"	308.0	308.0	308.0	19.0	N/A	158.7	105.0	276.0	33
1 1/4" X 1"	349.0	349.0	349.0	19.0	32.0	184.2	105.0	276.0	33

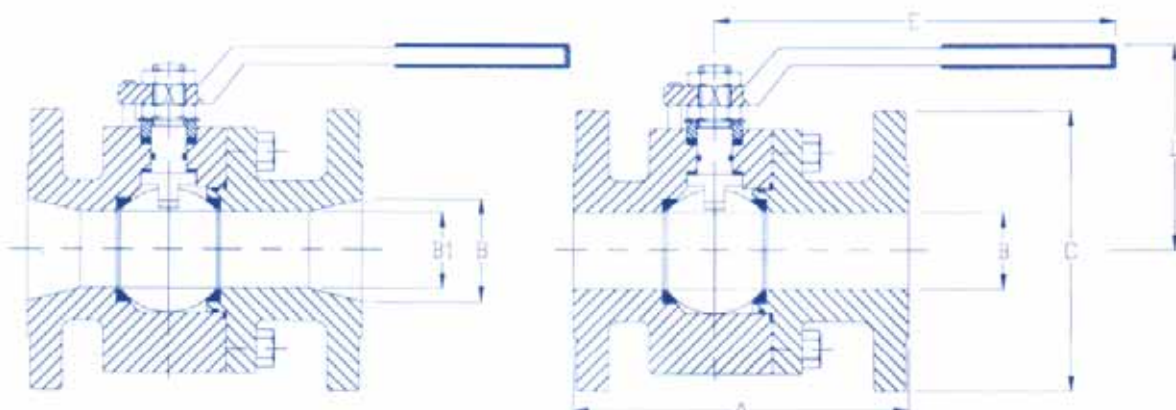

Technical Features

TRUNNION MOUNTED DESIGN



DESIGN

KVC Trunnion Mounted bolted construction Ball Valves are designed and manufactured in accordance with the latest industry standards. Our two and three design gives ease of maintenance on site.

In addition to Bolted construction, Trunnion Mounted valves are also available in Top Entry and Metal Seated design.

Special face to face dimensions can be supplied. All valves are available in Full or Reduced Bore, with Raised Face. Ring Type Joint, Hub End, Butt Weld or Socket end connections. Pressure rating is from ANSI 150 thru ANSI 2500.

Valves are supplied as Lever operated, Gear Operated or Actuated to customer's specification.



MATERIAL SELECTION

Valves are manufactured in a range of materials such as Carbon steel, Low Temp Carbon Steel, Stainless Steel, Duplex, Super Duplex, Monel, Inconel and other Special Alloys.



BODY / CAP

Trunnion Mounted valves are normally manufactured from forged rings, which ensures a high integrity seal between the components. Sealing is by O rings and Graphite rings. The Graphite ring continues to provide a seal in the event of a fire. O rings can be supplied suitable for AED applications.



SEAT

Independent seats with preloaded springs are always in contact with the Ball giving a perfect seal even at low pressure. The replaceable seat rings and soft inserts can be supplied in materials to suit most service conditions.

For very high temperatures, sealing is ensured by metal to metal seats whereby the Ball and Seats are coated with Tungsten Carbide and lapped together. Valves 2" and above have Sealant Injection system fitted as standard. This allows emergency sealing to be carried out in the event of damage to the soft seat.

Technical Features



STEM

Stems are manufactured separately from the Ball and feature an anti blow-out design. Stems are supported by PTFE lined bushes, which reduce valve torque. Stem sealing is by O rings and graphite rings. From 2" and above stems are supplied with sealant injection system.



BALL

Balls are supplied in Forged or Cast Stainless Steel, Duplex or Carbon Steel with ENP. The Trunnion Mounted design reduces operating torque and seat wear.



ANTI STATIC DEVICE

Electrical conductivity is achieved by fitting stainless steel balls between the Stem, Ball and Bonnet.



DOUBLE BLOCK AND BLEED

Valves are equipped with a vent plug, which allows the cavity to be relieved when pressure is applied to both sides of the Ball simultaneously.



TEST

Valves are tested in accordance with BS 6755 Pt 1, API 6D, AN 598 and ASME B16.34



FIRE TEST CERTIFICATION

Valves are designed and certified by an Independent Authority according to API 607, BS 6755 Pt2 and API 6FA.



EXTERNAL COATING

Carbon Steel valves are normally supplied with KVCstandard paint finish. Valves can also be unpainted or to customers specification.



ACCESSORIES

Include locking devices, pipe pups, extended bonnets and actuators. Suitable materials, components, seats and O rings can be supplied for Valves with Explosive Decompression or Cryogenic applications.

Trunnion Mounted Ball Valves

TWO PIECE TRUNNION MOUNTED • FULL AND REDUCED BORE • ASME 150												
API 6 D		TEST PRESSURE 425 PSI								MAX. WP. 275 PSI		APPROX WEIGHT KG
Size	A RF	A RTJ	A BWE	B	B1	C	D	E	F	G	H	
2" x 1 1/2"	177.8	190.5	215.9	50.0	38.1	152.0	80.0	144.0	250.0	LEVER OPERATED		15
2" X 2"	177.8	190.5	215.9	50.0	N/A	152.0	80.0	144.0	250.0		15	
3" X 2"	203.2	215.9	282.6	76.0	50.0	191.0	102.0	144.0	250.0		26	
3" X 3"	203.2	215.9	282.6	76.0	N/A	191.0	102.0	194.0	350.0		33	
4" X 3"	228.6	241.3	304.8	100.0	76.0	229.0	140.0	194.0	350.0		50	
4" X 4"	228.6	241.3	304.8	100.0	N/A	229.0	140.0	210.0	460.0		56	
6" X 4"	393.7	406.4	457.2	152.0	100.0	279.0	135.0	210.0	460.0		118	
6" X 6"	393.7	406.4	457.2	152.0	N/A	279.0	135.0	195.0	800.0		125	
6" X 6"	393.7	406.4	457.2	152.0	N/A	279.0	195.0	265.0	310.0	165.5	82.5	140
8" X 6"	457.2	469.9	520.7	203.0	152.0	343.0	195.0	284.0	310.0	165.5	82.5	150
8" X 8"	457.2	469.9	520.7	203.0	N/A	343.0	243.0	318.0	355.0	210.0	97.5	195
10" X 8"	533.4	546.1	558.8	254.0	203.0	406.0	243.0	318.0	355.0	210.0	97.5	230
10" X 10"	533.4	546.1	558.8	254.0	N/A	406.0	287.0	378.0	355.0	210.0	97.5	270
12" X 10"	609.6	622.3	635.0	305.0	254.0	483.0	287.0	378.0	355.0	210.0	97.5	278
12" X 12"	609.6	622.3	635.0	305.0	N/A	483.0	345.0	435.0	470.0	285.0	140.0	850
14" X 12"	685.8	689.5	762.0	337.0	305.0	533.0	345.0	445.0	470.0	285.0	140.0	480
14" X 14"	685.8	689.5	762.0	337.0	N/A	533.0	383.0	500.0	600.0	360.0	215.0	1060
16" X 14"	762.0	774.7	838.2	387.0	337.0	597.0	383.0	502.0	600.0	360.0	215.0	585
16" X 16"	762.0	774.7	838.2	387.0	N/A	597.0	448.0	560.0	600.0	360.0	215.0	1380
18" X 16"	863.6	876.3	914.4	438.0	387.0	635.0	448.0	560.0	600.0	360.0	215.0	890
18" X 18"	863.6	876.3	914.4	438.0	N/A	635.0	483.0	595.0	600.0	360.0	295.0	1155
20" X 18"	914.4	927.1	990.6	489.0	438.0	698.5	483.0	595.0	600.0	360.0	295.0	955
20" X 20"	914.4	927.1	990.6	489.0	N/A	698.5	538.0	660.0	600.0	360.0	295.0	1815
24" X 20"	1066.8	1079.5	1143.0	591.0	489.0	812.8	538.0	660.0	600.0	360.0	295.0	1650
24" X 24"	1066.8	1079.5	1143.0	591.0	N/A	812.8	627.0	745.0	600.0	360.0	295.0	2550

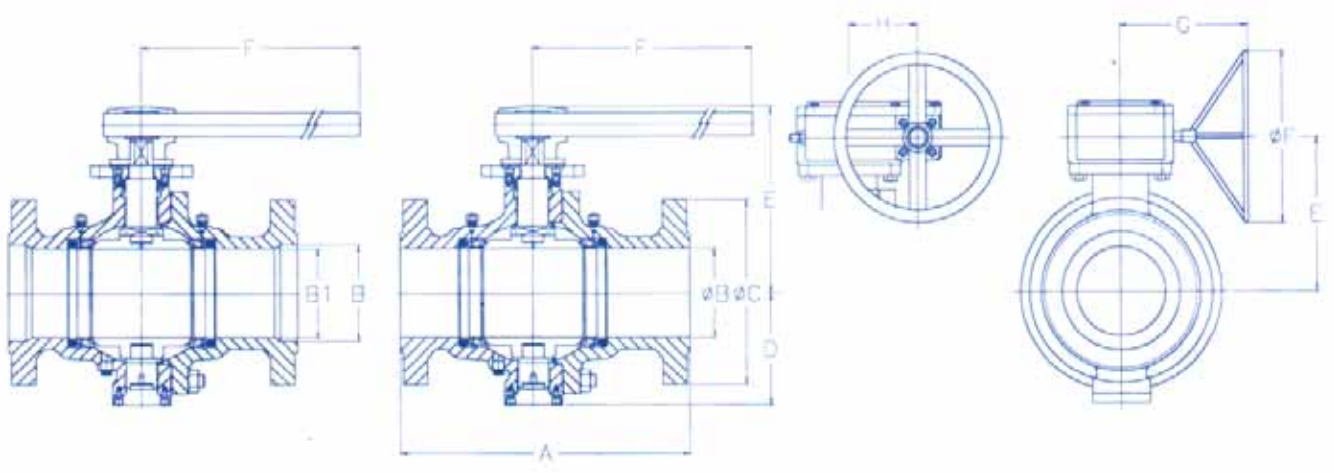

Trunnion Mounted Ball Valves

TWO PIECE TRUNNION MOUNTED • FULL AND REDUCED BORE • ASME 300													
API 6 D	TEST PRESSURE 1100 PSI										MAX. WP. 720 PSI		
Size	A RF	A RTJ	A BWE	B	B1	C	D	E	F	G	H	APPROX WEIGHT KG	
2" x 1 1/2"	215.9	231.78	215.9	50.0	38.1	165.0	90.0	144.0	250.0	LEVER OPERATED		18	
2" X 2"	215.9	231.78	215.9	50.0	N/A	165.0	90.0	144.0	250.0		24		
3" X 2"	282.6	298.45	282.6	76.0	50.0	210.0	115.0	144.0	250.0		35		
3" X 3"	282.6	298.45	282.6	76.0	N/A	210.0	115.0	194.0	350.0		44		
4" X 3"	304.8	320.68	304.8	100.0	76.0	254.0	135.0	194.0	350.0		65		
4" X 4"	304.8	320.68	304.8	100.0	N/A	254.0	135.0	210.0	460.0		75		
6" X 4"	403.2	419.10	457.2	152.0	100.0	318.0	170.0	210.0	460.0		105		
6" X 6"	403.2	419.10	457.2	152.0	N/A	318.0	170.0	195.0	800.0		125		
6" X 6"	403.1	152.00	318.0	152.0	N/A	318.0	195.0	265.0	1310.0		165.5	82.5	162
8" X 6"	501.0	517.53	520.7	203.0	152.0	381.0	195.0	265.0	310.0		165.5	82.50	200
8" X 8"	501.0	517.53	520.7	203.0	N/A	381.0	243.0	318.0	355.0	210.0	97.5	236	
10" X 8"	568.3	584.20	558.8	254.0	203.0	445.0	243.0	318.0	355.0	210.0	97.5	280	
10" X 10"	568.3	584.20	558.8	254.0	N/A	445.0	287.0	378.0	355.0	210.0	97.5	303	
12" X 10"	647.7	663.58	635.0	305.0	254.0	521.0	287.0	378.0	355.0	210.0	97.5	310	
12" X 12"	647.7	663.58	635.0	305.0	N/A	521.0	345.0	435.0	470.0	285.0	140.0	502	
14" X 12"	762.0	777.88	762.0	337.0	305.0	584.0	345.0	435.0	470.0	285.0	140.5	520	
14" X 14"	762.0	777.88	762.0	337.0	N/A	584.0	383.0	500.0	600.0	360.0	215.0	602	
16" X 14"	838.2	854.08	838.2	387.0	337.0	648.0	383.0	500.0	600.0	360.0	215.0	620	
16" X 16"	838.2	854.08	838.2	387.0	N/A	648.0	448.0	560.0	600.0	360.0	215.0	1001	
18" X 16"	914.4	930.28	914.4	438.0	387.0	711.0	448.0	560.0	600.0	360.0	215.0	1025	
18" X 18"	914.4	930.28	914.4	438.0	N/A	711.0	483.0	595.0	600.0	360.0	295.0	1155	
20" X 18"	990.6	1009.65	990.6	489.0	438.0	775.0	483.0	595.0	600.0	360.0	295.0	1180	
20" X 20"	990.6	1009.65	990.6	489.0	N/A	775.0	538.0	660.0	600.0	360.0	295.0	1815	
24" X 20"	1143.0	1165.23	1143.0	597.0	489.0	914.0	538.0	660.0	600.0	360.0	295.0	1950	
24" X 24"	1143.0	1165.23	1143.0	597.0	N/A	914.0	627.0	745.0	600.0	360.0	295.0	2550	

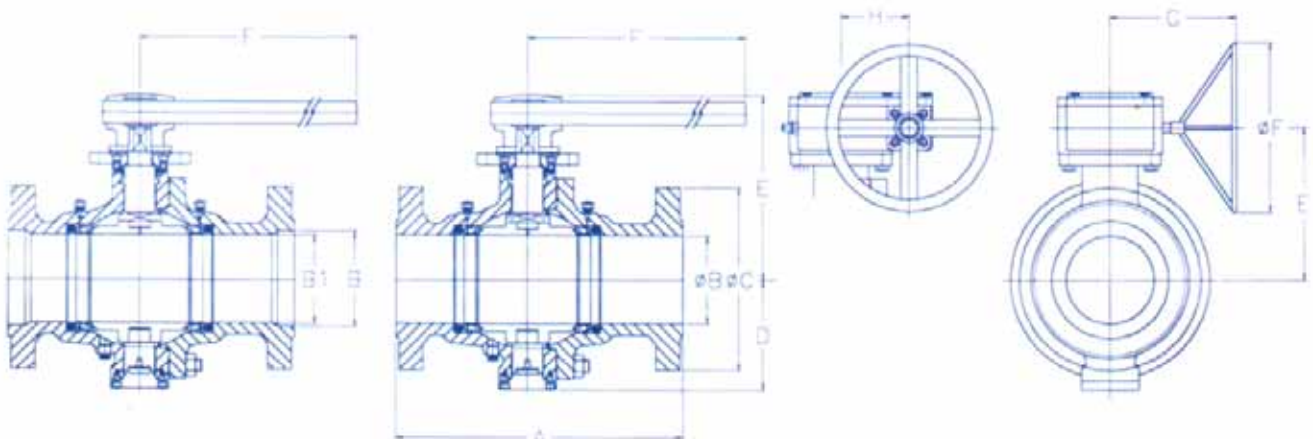

Trunnion Mounted Ball Valves

TWO PIECE TRUNNION MOUNTED • FULL AND REDUCED BORE • ASME 600													
API 6 D	TEST PRESSURE 2175 PSI										MAX. WP. 1440 PSI		
SIZE	A RF	A RTJ	A BWE	B	B1	C	D	E	F	G	H	APPROX WEIGHT KG	
2" X 2"	292.1	295.28	292.1	50.0	N/A	165.0	N/A	144.0	250.0	LEVER OPERATED		27	
2 1/2" X 2 1/2"	330.2	330.20	333.4	65.0	N/A	190.0	N/A	178.0	460.0		40		
3" X 2"	355.6	358.78	355.6	76.0	50.0	210.0	N/A	194.0	460.0		46		
3" X 3"	355.6	358.78	355.6	76.0	N/A	209.5	N/A	194.0	460.0		53		
4" X 3"	431.8	434.98	431.8	100.0	76.0	273.0	N/A	194.0	460.0		120		
4" X 4"	431.8	434.98	431.8	100.0	N/A	273.0	165.0	276.0	800.0		93		
6" X 4"	558.8	561.98	558.8	152.0	100.0	356.0	165.0	276.0	800.0		240		
6" X 6"	558.8	561.98	558.8	152.0	N/A	356.0	207.0	327.0	800.0		180		
4" X 4"	431.8	434.9	431.8	100.0	N/A	273.0	165.0	237.0	310.0		165.5	82.5	113
6" X 4"	558.8	561.9	558.8	152.0	100.0	356.0	165.0	237.0	310.0		165.5	82.5	120
6" X 6"	558.8	561.9	558.8	152.0	N/A	356.0	207.0	288.0	355.0	210.0	97.5	200	
8" X 6"	660.4	663.58	660.4	203.0	152.0	419.0	207.0	288.0	355.0	210.0	97.5	205	
8" X 8"	660.4	663.58	660.4	203.0	N/A	419.0	260.0	360.0	470.0	285.0	140.0	340	
10" X 8"	787.4	790.58	787.4	254.0	203.0	508.0	260.0	360.0	470.0	285.0	140.0	350	
10" X 10"	787.4	790.58	787.4	254.0	N/A	508.0	313.0	430.0	600.0	360.0	215.0	552	
12" X 10"	838.2	841.38	838.2	305.0	254.0	559.0	313.0	430.0	600.0	360.0	215.0	605	
12" X 12"	838.2	841.38	838.2	305.0	N/A	559.0	358.0	470.0	600.0	360.0	215.0	782	
14" X 12"	1330.0	892.18	889.0	337.0	305.0	603.0	358.0	470.0	600.0	360.0	215.0	820	
14" X 14"	889.0	892.18	889.0	337.0	N/A	603.0	418.0	530.0	600.0	360.0	215.0	850	
16" X 14"	990.6	993.78	990.6	387.0	337.0	686.0	418.0	530.0	600.0	360.0	215.0	980	
16" X 16"	990.6	993.78	990.6	387.0	N/A	686.0	472.0	611.0	800.0	550.0	240.0	1580	
18" X 16"	1092.2	1095.38	1092.2	438.0	387.0	743.0	472.0	611.0	800.0	550.0	240.0	1250	
18" X 18"	1092.2	1095.38	1092.2	438.0	N/A	743.0	540.0	698.0	800.0	570.0	283.0	2170	
20" X 18"	1193.8	1200.15	1193.8	489.0	438.0	812.8	540.0	698.0	800.0	570.0	283.0	1700	
20" X 20"	1193.8	1200.15	1193.8	489.0	N/A	812.8	960.0	685.0	800.0	620.0	283.0	2100	
24" X 20"	1397.0	1406.53	1397.0	591.0	489.0	939.8	960.0	685.0	800.0	620.0	283.0	2300	

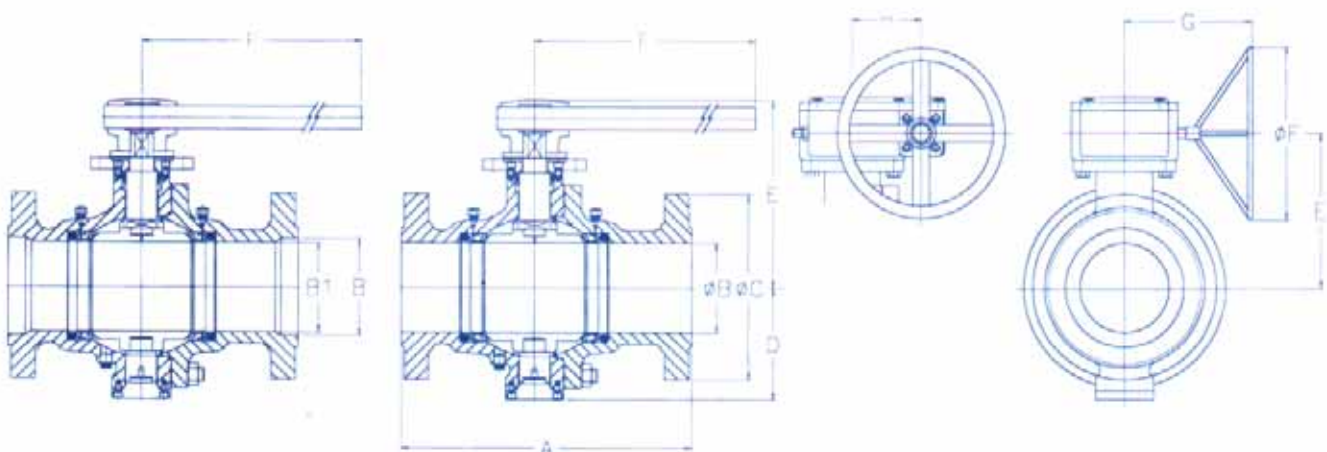

Trunnion Mounted Ball Valves

TWO PIECE TRUNNION MOUNTED • FULL AND REDUCED BORE • ASME 900												
API 6 D			TEST PRESSURE 3250 PSI						MAX. WP. 2160 PSI			
SIZE	A RF	A RTJ	A BWE	B	B1	C	D	E	F	G	H	APPROX WEIGHT KG
2" X 1 1/2"	368.30	371.48	368.30	50.0	38.0	215.9	158.0	740.0	LEVER OPERATED			65
2" X 2"	368.30	371.48	368.30	50.0	N/A	215.9	158.0	740.0				65
3" X 2"	381.00	384.18	381.00	76.0	50.0	241.3	158.0	740.0				73
3" X 3"	381.00	384.18	381.00	76.0	N/A	241.3	230.0	830.0				80
4" X 3"	457.20	460.38	457.20	100.0	76.0	292.0	230.0	830.0				120
4" X 4"	457.20	460.38	457.20	100.0	N/A	292.0	140.0	235.0	500.0	230.0	66.0	155
6" X 4"	609.60	612.78	609.60	152.0	100.0	349.2	140.0	235.0	500.0	230.0	66.0	260
6" X 6"	609.60	612.78	609.60	152.0	N/A	349.2	180.0	320.0	600.0	365.0	130.0	410
8" X 6"	736.60	739.78	736.60	203.0	152.0	469.9	180.0	320.0	600.0	365.0	130.0	470
8" X 8"	736.60	739.78	736.60	203.0	N/A	469.9	245.0	360.0	500.0	405.0	211.0	840
10" X 8"	838.20	841.38	838.20	254.0	203.0	546.1	245.0	360.0	500.0	405.0	211.0	920
10" X 10"	838.20	841.38	838.20	254.0	N/A	546.1	285.0	401.0	600.0	405.0	211.0	1100
12" X 10"	965.20	968.38	965.20	304.0	254.0	609.6	285.0	401.0	600.0	405.0	211.0	1320
12" X 12"	965.20	968.38	965.20	304.0	N/A	609.6	320.0	455.0	500.0	502.0	211.0	1705
14" X 12"	1028.70	1038.23	1028.7	355.0	304.0	641.3	320.0	455.0	500.0	502.0	211.0	1920
14" X 14"	1028.70	1038.23	1028.7	355.0	N/A	641.3	335.0	425.0	500.0	502.0	265.0	2020
16" X 14"	1130.30	1139.83	1130.3	406.0	355.0	705.0	335.0	425.0	500.0	502.0	265.0	2410
16" X 16"	1130.30	1139.83	1130.3	406.0	N/A	705.0	365.0	620.0	600.0	420.0	265.0	3200
18" X 16"	1219.20	1231.90	1219.2	457.0	406.0	787.4	365.0	620.0	600.0	420.0	265.0	3550
18" X 18"	1219.20	1231.90	1219.2	457.0	N/A	787.4	405.0	660.0	600.0	520.0	66.0	4670
20" X 16"	1320.80	1333.50	1320.8	508.0	406.0	857.2	405.0	620.0	600.0	520.0	66.0	4020
20" X 20"	1320.80	1333.50	1320.8	508.0	N/A	857.2	435.0	787.0	600.0	520.0	66.0	4800
24" X 20"	1549.40	1568.45	1549.4	610.0	508.0	1041.4	435.0	787.0	600.0	520.0	66.0	5000
24" X 24"	1549.0	1568.45	1549.4	610.0	N/A	1041.4	530.0	900.0	600.0	520.0	205.0	6020

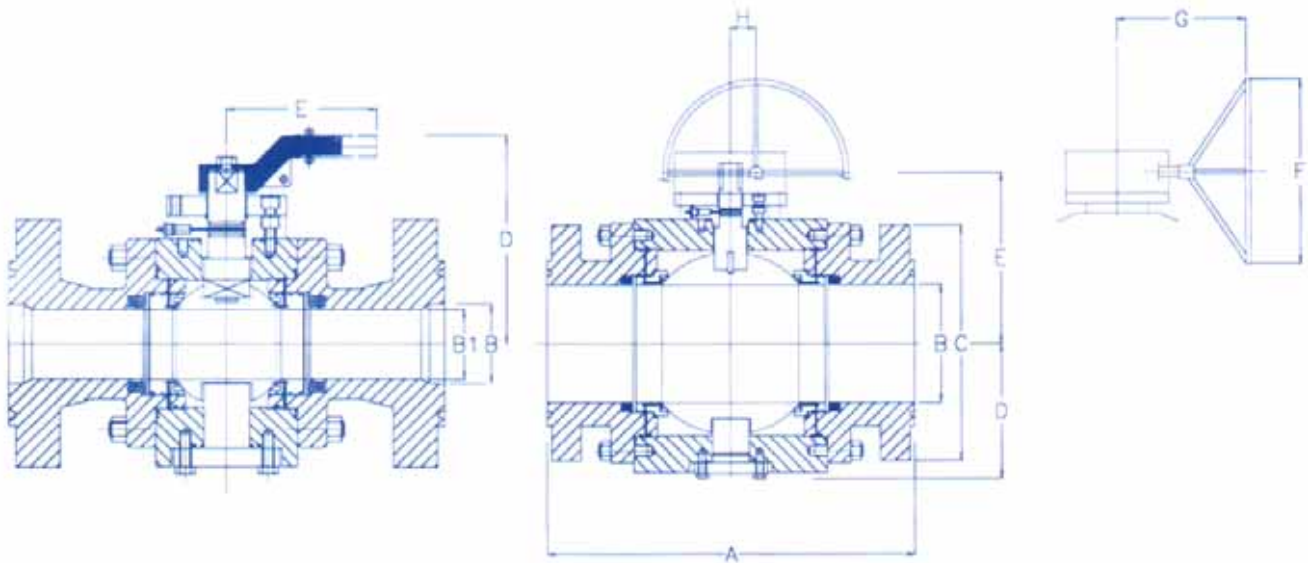

Trunnion Mounted Ball Valves

TWO PIECE TRUNNION MOUNTED • FULL AND REDUCED BORE • ASME 1500												
API 6 D			TEST PRESSURE 5400 PSI						MAX. WP. 3600 PSI			
Size	A RF	A RTJ	A BWE	B	B1	C	D	E	F	G	H	APPROX WEIGHT KG
2" X 1 1/2"	368.3	371.48	368.3	50.0	38.1	215.9	195.0	740.0	LEVER OPERATED			66
2" X 2"	368.3	371.48	368.3	50.0	N/A	215.9	195.0	740.0				66
3" X 2"	469.9	473.08	469.9	76.0	50.0	266.7	195.0	740.0				88
3" X 3"	469.9	473.08	469.9	76.0	N/A	266.7	225.0	830.0				120
4" X 3"	546.1	549.28	546.1	100.0	76.0	311.1	225.0	830.0				132
4" X 4"	546.1	549.28	546.1	100.0	N/A	311.1	169.0	260.0	500.0	280.0	130.0	182
6" X 4"	704.85	711.20	704.85	146.0	100.0	393.7	210.0	260.0	500.0	280.0	130.0	198
6" x 6"	704.85	711.20	704.85	146.0	N/A	393.7	250.0	405.0	600.0	360.0	130.0	520
8" X 6"	831.85	841.38	831.85	194.0	146.0	482.6	250.0	405.0	600.0	360.0	130.0	675
8" X 8"	831.85	841.38	831.85	194.0	N/A	482.6	275.0	460.0	500.0	395.0	182.0	1215
10" X 8"	990.6	1000.13	990.6	241.0	194.0	584.2	275.0	460.0	500.0	395.0	182.0	1420
10" X 10"	990.6	1000.13	990.6	241.0	N/A	584.2	305.0	565.0	600.0	420.0	182.0	1900
12" X 10"	1130.3	1146.18	1130.3	289.0	241.0	673.1	305.0	565.0	600.0	420.0	182.0	2200
12" X 12"	1130.3	1146.18	1130.3	289.0	N/A	673.1	330.0	620.0	800.0	490.0	256.0	2600
14" X 12"	1257.3	1276.35	1257.3	318.0	289.0	749.3	330.0	620.0	800.0	490.0	256.0	2925
14" X 14"	1257.3	1276.35	628.65	318.0	N/A	749.3	360.0	670.0	600.0	510.0	256.0	3495
16" X 14	1384.3	1406.53	1384.3	362.0	318.0	825.5	360.0	670.0	600.0	510.0	256.0	3750
16" X 16"	1384.3	1406.53	1384.3	362.0	N/A	825.5	410.0	790.0	800.0	570.0	310.0	4600

TWO PIECE TRUNNION MOUNTED • FULL AND REDUCED BORE • ASME 2500												
API 6 D			TEST PRESSURE 9000 PSI						MAX. WP. 6000 PSI			
Size	A RF	A RTJ	A BWE	B	B1	C	D	E	F	G	H	APPROX WEIGHT KG
2" X 1 1/2"	450.85	454.03	450.85	44.0	30.0	235.0	206.0	670.0	LEVER OPERATED			85
2" X 2"	450.85	454.03	450.85	44.0	N/A	235.0	206.0	720.0				91
3" X 2"	577.85	584.20	577.85	64.0	44.0	304.8	206.0	720.0				155
3" X 3"	577.85	584.20	577.85	64.0	N/A	304.8	175.0	220.0	500.0	230.0	86.0	248
4" X 3"	673.1	682.63	673.1	89.0	64.0	355.6	175.0	220.0	500.0	230.0	86.0	335
4" X 4"	673.1	682.63	673.1	89.0	N/A	355.6	195.0	265.0	400.0	292.0	105.0	410
6" X 4"	914.4	927.1 I	914.4	133.0	89.0	482.6	195.0	265.0	400.0	292.0	105.0	650
6" x 6"	914.4	927.1 I	914.4	133.0	N/A	482.6	255.0	420.0	600.0	355.0	130.0	820
8" X 6"	1022.35	1038.23	1022.4	181.0	133.0	552.5	255.0	420.0	600.0	355.0	130.0	1400
8" X 8"	1022.35	1038.23	1022.4	181.0	N/A	552.5	260.0	480.0	600.0	480.0	130.0	2090
10" X 8"	1270.0	1292.23	1270.0	225.0	181.0	673.1	260.0	480.0	600.0	480.0	130.0	2600
10" X 10"	1270.0	1292.23	1270.0	225.0	N/A	673.1	310.0	550.0	800.0	560.0	182.0	2815
12" X 10"	1422.4	1444.63	142.4	267.0	225.0	762.0	310.0	550.0	800.0	560.0	182.0	3670
12" X 12"	1422.4	1444.63	142.4	267.0	N/A	762.0	375.0	620.0	800.0	610.0	182.0	4100

Trunnion Mounted Ball Valves

TRUNNION MOUNTED • FULL BORE • TOP ENTRY BALL VALVES

Integral flanges - End to End According to API 6D Flange Dimensions to ASME B16.5

FULL BORE	DN	50		80		100		150		200		250		
		IN	2"	3"	4"	6"	8"	10"						
		mm	in.	mm	in.	mm	in.	mm	in.	mm	in.	mm	in.	
Class 150	A	178	7.00	203	7.99	229	9.01	394	15.51	457	17.99	533	20.98	
Class 300	A	216	8.50	283	11.14	305	12.00	403	15.86	502	19.76	568	22.36	
Class 600z	A	292	11.49	356	14.01	432	17.00	559	22.00	660	25.98	787	30.98	
Class 900	A	369	14.52	381	15.00	458	18.03	610	24.01	737	29.01	839	33.03	
Class 1500	A	368	14.48	470	18.50	546	21.49	705	27.75	832	32.75	991	39.00	
Centre To Top	Class 150	B	140	5.51	190	7.48	280	11.02	295	11.61	330	12.99	400	15.74
	Class 300	B	200	7.87	240	9.44	280	11.02	295	11.61	330	12.99	420	16.53
	Class 600	B	195	7.67	240	9.44	280	11.02	305	12.00	400	15.74	435	17.12
	Class 900	B	200	7.87	240	9.44	280	11.02	350	13.77	390	15.35	480	18.89
	Class 1500	B	205	8.07	210	8.26	245	9.64	335	13.18	437	17.2	502	19.76
Centre To Bottom	Class 150	C	90	3.54	105	4.13	166	6.53	175	6.88	210	8.26	250	9.84
	Class 300	C	120	4.72	130	5.11	150	5.90	175	6.88	210	8.26	270	10.62
	Class 600	C	110	4.33	110	4.33	175	6.88	195	7.67	280	11.02	285	11.22
	Class 900	C	120	4.72	130	5.11	175	6.88	220	8.66	260	10.23	310	14.20
	Class 1500	C	120	4.72	125	4.92	160	6.29	255	10.03	340	13.38	381	15.00

TRUNNION MOUNTED • REDUCED BORE • TOP ENTRY BALL VALVES

Integral flanges - End to End According to API 6D Flange Dimensions to ASME B16.5

FULL BORE	DN	50 X 40		80 X 50		100 X 80		150 X 100		200 X 150		250 X 200		300 X 250		
		IN	2" X 1 1/2"	3" X 2"	4" X 3"	6" X 4"	8" X 6"	10" X 8"	12" X 10"							
		mm	in.	mm	in.	mm	mm	in.	in.	mm	in.	mm	in.	m	in.	
Class 150	A	178	7.00	203	7.99	229	9.01	394	15.51	457	17.99	533	20.98	610	24.0	
Class 300	A	216	8.50	283	11.14	305	12.00	403	15.86	502	19.76	568	22.36	648	25.51	
Class 600	A	292	11.49	356	14.01	432	17.00	559	22.00	660	25.98	787	30.98	838	32.99	
Class 900	A	369	14.52	381	15.00	458	18.03	610	24.01	737	29.01	839	33.03	966	38.03	
Class 1500	A	368	14.48	470	18.50	546	21.49	705	27.75	832	32.75	991	39.01	1131	44.5	
Centre to Top	Class	B	209	8.22	140	5.51	190	7.48	280	11.02	295	11.61	330	12.99	400	15.74
	Class	B	209	8.22	200	7.87	240	9.44	280	11.02	295	11.61	330	12.99	420	16.53
	Class	B	209	8.22	195	7.67	240	9.44	280	11.02	305	12.00	400	15.74	435	17.12
	Class	B	215	8.46	200	7.87	240	9.44	280	11.02	350	13.77	390	15.35	480	18.89
	Class 1500	B	220	8.66	205	8.07	210	8.26	245	9.64	335	13.18	437	17.2	502	19.76
Centre to Bottom	Class	C	70	2.75	90	3.54	105	4.13	166	6.53	175	6.88	210	8.26	250	9.84
	Class	C	70	2.75	120	4.72	130	5.11	150	5.90	175	6.88	210	8.26	270	10.62
	Class	C	70	2.75	110	4.53	110	4.33	175	6.88	195	7.67	280	11.02	285	11.22
	Class	C	80	3.14	120	4.72	130	5.11	175	6.88	220	8.66	260	10.23	310	14.20
	Class 1500	C	90	3.54	120	4.72	125	4.92	160	6.29	255	10.03	340	13.38	380	15.01

RATINGS Carbon Steel

Class 150-275 p.s.i. @ 100°F-Seat PTFE + Graphite
 Class 300-720 p.s.i. @ 100°F-Seat PTFE + Graphite
 Class 600-1440 p.s.i. @ 100°F-Seat PTFE + Graphite
 Class 900-2160 p.s.i. @ 100°F-Seat Nylon
 Class 1500-3600 p.s.i. @ 100°F-Seat Nylon

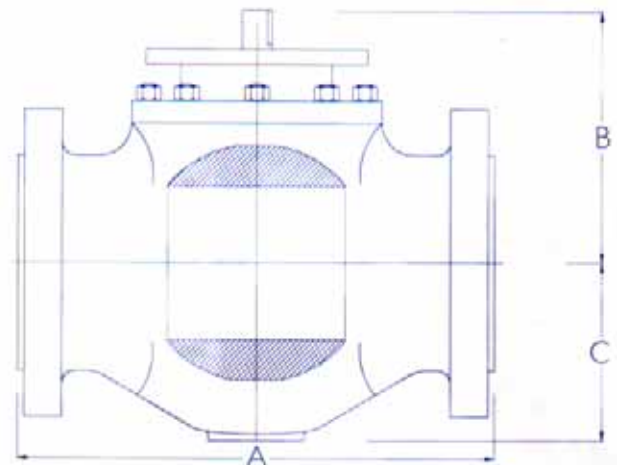

Technical Features

DOUBLE BLOCK AND BLEED

Ball in Open Position

This feature is required to verify the seats sealing condition. With the ball in fully open position and with pressure in the line, the medium trapped in the body cavity can be relieved through the vent plug. In this way, the eventual leakage of the seal rings can be evaluated.

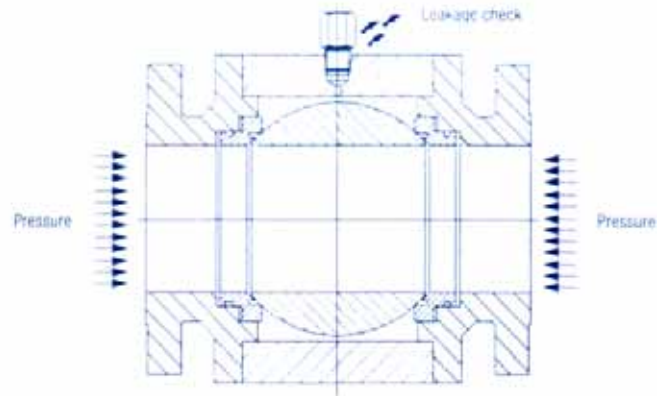

SEALANT INJECTION DETAIL

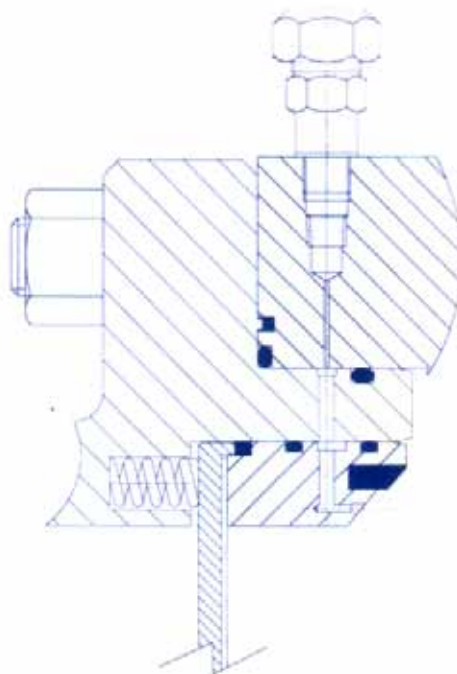

Materials

SEAT MATERIALS



PCTFE

Cable of higher loads than PTFE. Good low temperature strength, Excellent chemical resistance.



FILLED PTFE

Mixed with an inert filler at the processing stage to give a stiffer material than virgin polymer, this material gives good chemical resistance and low coefficient of friction.



DEVLON V (MONOCAST NYLON)

For services higher than filled PTFE, Devlon V gives good resistance to oils, greases and solvents. Its low water absorption gives superior dimensional stability.



PES

Good load bearing material at higher temperatures particularly when glass fibres



PEEK

are added. Good resistance to acids, cleaning solvents, oils and greases.
This material is an abrasion resistant high performance thermo plastic which retains good tensile and flexural properties at temperatures in excess of plus 250 deg C.

SEAL MATERIALS



VITON

Shore hardness 90. Suitable for low, medium and high temperature applications.



NITRILE

Shore hardness 90. Suitable for medium to low temperature applications.



FLUROSILICONE

Shore hardness 70. Suitable for low temperature applications.



EXPLOSIVE DECOMPRESSION VITON

Shore hardness 90. Suitable for medium and high temperature applications.



OTHERS ON APPLICATION

FIRESAFE MATERIAL

Natural Graphite is purified, expanded, and pressed into a typical hexagonal crystalline structure of Graphite which remains permanently flexible.

Supplied in moulded ring form it is suitable for temperatures of minus 250 deg C to plus 2500 deg C in non-oxidising atmosphere and up to plus 500 deg C in oxygen. Operating experience at pressure up to 350 bar. Its features include natural resilience, self lubricating, almost chemically inert, no fillers or binders and no structural change against pressure temperature or time.

Weights & Measures

Multiply	by	To obtain
----------	----	-----------

LENGTH		
centimetre	0.03281	foot (ft)
centimetre	0.39370	Inch
foot	0.3048	metre (m)
foot	304.8	millimetre (mm)
inch	25.4	millimetre
microinch	0.0254	micron (μA m)
micron (micronetre)	39.37008	microninch
millimetre	0.039370	inch

AREA		
centimetre ²	0.15500	inch ²
centimetre ²	0.00108	foot ²
foot ²	0.09290	metre ² (m ²)
foot ²	929.0304	centimetre ² (mm ²)
inch ²	645.16	millimetre ² (mm ²)
metre ²	1550.003	inch ²
metre ²	10.76391	foot ²
millimetre ²	0.00155	inch ²

VOLUME		
centimetre ³	0.06102	Inch
foot ³	0.02832	metre ³ (m ³)
foot ³	28.31685	litre
gallon (U.K. liquid)	4.54609	litre
gallon (U.K liquid)	3.78541	litre
inch ³	16.38706	centimetre ³ (cm ³)
litre	0.021997	gallon (U.K. liquid)
litre	0.26417	gallon (U.S. liquid)

VELOCITY and FLOW		
centimetre/ minute	0.39307	inch/ minute
foot / minute	18.288	metre / hour
foot / minute	0.3048	metre / minute
foot ³ / minute	28.31685	litre / minute
gallon (U.S. liquid)	3.78541	litre / minute
litre / minute	0.035315	foot ³ / minute
litre / minute	0.26417	gallon (U.S.)/minute

MASS and DENSITY		
gram(=0.001kg)	0.0352274	ounce (avoirdupois)
kilogram	2.20462	Pound
kilogram / metre ³	0.06243	pound / foot ³
kilogram / metre ³	0.00835	pound /gallon (U.S.)
ounce (avoirdupois)	28.34952	gram
pound (avoirdupois)	0.45359	kilogram (kg)
ton(long=2240Lb)	1016.047	Kilogram
ton(short=2000Lb)	907.1847	Kilogram

FORCE and FORCE/LENGTH		
dyne	0.00001	newton
kilogram-force	9.80665	newton
newton	0.10197	kilogram-force
newton	0.22481	pound-force
newton-metre	0.00571	pound-inch
pound-force	4.44822	newton
pound-inch	175.1268	newton-metre (N/m)
pound-foot	14.59390	newton-metre

Multiply	by	to obtain
----------	----	-----------

BENDING MOMENT or TORQUE		
kilogram-metre	9.80665	newton-metre(M-m)
kilogram-metre	7.23299	pound-foot
newton-metre	0.73756	pound-foot
newton-metre	0.10197	kilogram-metre
pound-foot	1.35582	newton-metre

PRESSURE and STRESS		
atmosphere (atm)	101325	pasca(Pa)
atmosphere	1.101325	bar
atmosphere	1.0333	kilogram/ centimetre ²
bar	0.98692	atmosphere
bar	1.02668	kilogram/ centimetre ²
bar	100000	Pascal (N/ m ²)
bar	14.50377	pound / inch ²
kilogram/ centimetre ²	0.968	atmosphere
kilogram/ centimetre ²	0.98066	bar
kilogram/ centimetre ²	98066	Pascal (N/ m ²)
kilogram/ centimetre ²	14.22334	Pound / inch ²
kilogram/ metre ²	9.80665	Pascal
newton/ metre ² (N/ m ²)	0.000145	Pound / inch ²
newton/ metre ² (or Pa)	0.10197	kilogram/ metre ²
newton/metre	0.000010197	kilogram/ centimetre ²
Pascal (N/M)	0.0000987	atmosphere
Pascal	0.00001	bar
kPa	0.01	bar
Mpa	10	bar
pound / inch ²	0.06895	bar
pound / inch ²	6895	Pa
pound / inch ²	0.07031	kilogram/ centimetre ²
pound / inch ²	0.06805	atmosphere

ENERGY, WORK and POWER		
Btu (internat.)	1055.056	joule(J)
calorie	4.19002	joule
foot-pound	1.35582	joule
kilogram-metre	9.80665	joule
joule	0.73756	foot-pound
joule	0.101972	kilogram-metre
foot-pound/hour	0.0003766	watt(W)
horsepower(550ft-lb/s)	0.7457	kilowatt(KW)
horsepower(electric)	746	watt
kilowatt	1.34102	horsepower(550ft-lb/s)

MISCELLANEOUS		
atmosphere (atm)	760	mm Hg at 32°F
atmosphere	129.92	inch Hg at 32°F
atmosphere	10330	mm H2O at 60° F
bar	14070	pound / inch ²
bar	750	torr
bar	29.53	inch Hg at 32°F
feet or water(at 60°F)	0.8843	inch Hg at 60°F
feet or water	0.4331	pound / inch ²
inch of Hg (at 60°F)	0.0003766	atmosphere
inch of Hg	1.131	feet or water
inch of Hg	0.4898	pound / inch ²
torr(and mmHg)	0.0013116	atmosphere
torr	0.001333	bar(or 133.6Pa)
torr	0.00136	kilogram/ centimetre ²
torr	0.03937	inch Hg at 32°F
torr	13.59	mm H2O
torr	0.01934	pound / inch ²
torr.1/sec	1.316	atm.cc/sec(or Std.cc/s)
atm.cc/sec	0.76	torr.1/sec
torr.1/sec	1000	Lusec
Lusec	0.0001	torr.1/sec
dro of water or bubble	16	centimetre ²

Agents & Distributors

Worldwide Network of Agents & Distributors:

Asian & Middle East Agents

Singapore : **Federal Hardware Engineering Co Pte Ltd:** 47/49, Genting Road Singapore 349489
Tel: ++65 747 8118 **Fax:** ++65 743 0690 & 745 0048 **E-mail:** Admin@fedsin.com.sg **Webpage:** <http://www.federal.com.sg>

Malaysia: **Anugerah Bakti Supplies Sdn Bhd:** No. 5-2A Jalan Pandan Indah • 4/34 pandan Indah • 55100 Kuala Lumpur • Malaysia
(East & West)
Crystal Progress Sdn Bhd: 33A Jalan Sulaimon 1 • Taman Putra Sulaiman • 68000 Ampang Selangor Darul Ehsan • Malaysia
Tel: 60-3 4270 6666 **Fax:** 60-3 4270 6777 **E-mail:** crystalprogress@pd.jaring.my

Indonesia: **PT Fedsin Nusa Utama:** Jln Bendungan Hilir Raya no. 60 • Jakarta 10210 • Indonesia
Tel: 62-21 570 6808 **Fax:** 62-21 570 6783 **E-mail:** fedsin@indosat.net.id

PT Astina Perma Indah: Jl.Karang Anyar Permai 53-Blok A 10 • Jakarta Pusat • 10740 Indonesia
Tel: ++ 6221-624 9009 **Fax:** ++6221-624 9517

Philippines: **Federal Phil Nippon Flow Controls Inc:** Suite 705 Royal Plaza • Twin Tower 648 Remedios Street • Malate • Manila • Philippines
Tel: ++ 632-400 5778 **Fax:** ++ 632-400 5778

Thailand: **Alton Internatinal (Thailand) Co Ltd:** 48/168 Centre Place • Moo 1 Ramkhamhaeng Road • Saphan Soong • Bangkok 10240 • Thailand
Tel: ++ 662-372 3355 **Fax:** ++ 662-372 3359 **E-mail:** alton@alton.co.th

Vietnam : **Lephuco Ltd:** I0E/7 Le Minh Xuan St. Word 7 • Tan Binh Dist. • Ho Chi Minh City • Vietnam
Tel: 84-8 971 0815 **Fax:** 84-8 971 0814 **E-mail:** vnthang@fmail.vnn.vn

P R. China: **Federal –Beijing:** 5E No. 2 Building, Hua Ao Center • No. 31 Zhi Zhu Yuan Road • Hai Dian District, Baijing 100089 P. R. China
Tel: + +86-10 6871 8240 **Fax:** ++86-10 6871 8140 **E-mail:** fbj@ht.rol.cn.net

Federal -Dalian: Rm No: 1208, Jin Yang House • No. 3, Shi Ji Street • Dalian 116001 • P. R. China
Tel: ++ 86-411259 2384 **Fax:** ++ 86-411259 2384 **E-mail:** feddl@online.ln.cn

Federal –Tianjing : Block 56 Room 506 • Bin Hai Xin Cun • Tanggu District • Tianjin 300452 • P. R. China
Tel: ++ 86-22 25801228 **Fax:** ++ 86-22 2580 1228

Brunei: **Sahid Sdn Bhd:** No: 58 Lot 3275 Simpang 58 • Jalan Jaya Negara KA 1931 • Kuala Belait KA 1131 • Negara Brunei Darussalam
Tel: 673-3-342 860 **Fax:** 673-3-333 484

Pakistan: **Usman Enterprise:** Siddique Wahab Road • Lea Market, Karachi-74000 • Pakistan
Tel: 92-21 776 8024 **Fax:** 42-21 777 5875 **E-mail:** kath@khi.compol.com

UAE: **Fedsin Oilfield Equipment Co Ltd (L.L.C.):** P.O. Box 60333; 215/14 • Al Ramoul, Rashidiya, Dubai • United Arab Emirates
Tel: 971-4856 430 **Fax:** 971-4 856 429 **E-mail:** fedsin@emirates.net.ae
